

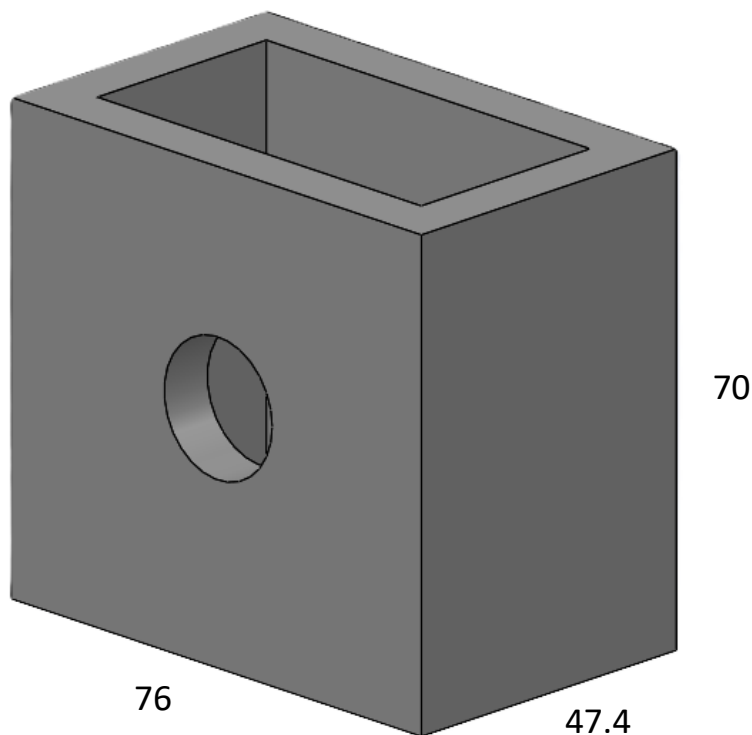

<b>Clasificación</b>	Arquetas	<b>Modelo</b>	Imbornal
----------------------	----------	---------------	----------



## DIMENSIONES

(cotas en cm)

H (INT)	A (INT)	F (INT)	H (EXT)	A (EXT)	F (EXT)	PESO		RESISTENCIA	DIMENSIONES DE LA BOCA	
						C / F	S / F		Longitud	Anchura
60	67.3	30	70	76	47.4	350kg	300kg	300 kg/cm <sup>2</sup>	600	300

## CARACTERÍSTICAS TÉCNICAS

<b>Denominación de Producto:</b>	Arqueta Imbornal de hormigón prefabricado
<b>Armadura:</b>	No
<b>Tipo de hormigón:</b>	HM-30N/mm
<b>Tipo de cemento:</b>	CEM I 52.5 SR

Marcado: **NORMA UNE-EN 13369**  
ISO-9001-2015



C/San Blas, 80  
18650 Dúrcal, Granada  
958 780 304  
info@prefabricadossanblas.com