

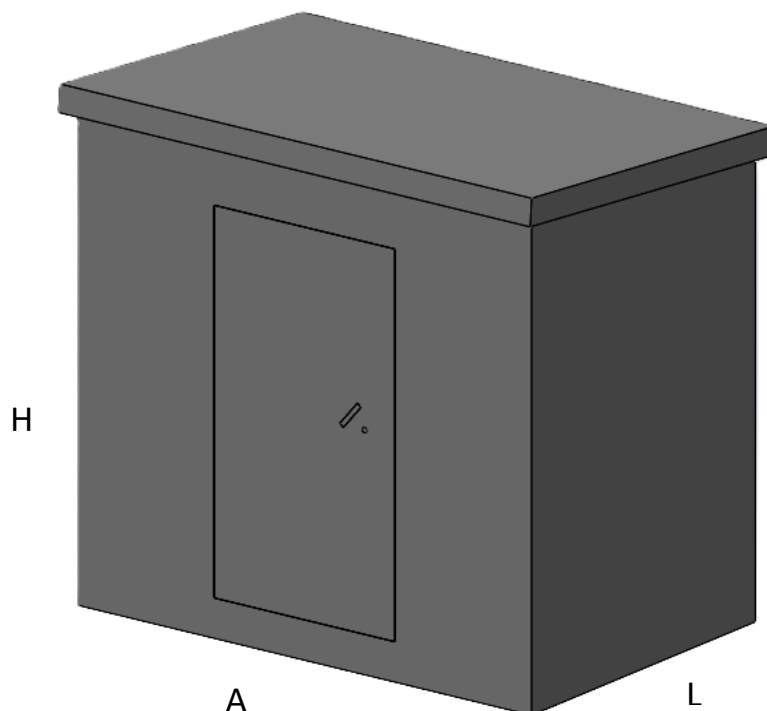

Clasificación	Casetas Prefabricadas	Modelo	200x130x197
----------------------	-----------------------	---------------	-------------

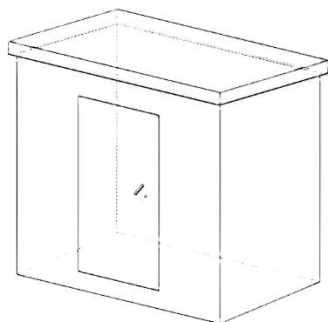

DIMENSIONES

(cotas en Cm)

MODELO	A	L	H	G	PESO (Ud)
Caseta 2x1.3x1.97	200 ±10	130 ±10	197 ±10	100	2.400Kg

CARACTERÍSTICAS TÉCNICAS

Denominación de Producto:	Caseta prefabricada de hormigón 200x130x197
Armadura:	Mallazo estructural
Tipo de hormigón:	HA-30 SR/S1/20/IV+F
Tipo de cemento:	CEM I 52.5 SR

Marcado: **NORMA UNE-EN 14992**
ISO-9001-2015



C/San Blas, 80
18650 Dúrcal, Granada
958 780 304
info@prefabricadossanblas.com